

Clausing **EVS MILLS**



Affordable, Heavy-duty Electronic Variable Speed (EVS) Milling Machines...

[Overview](#)

[Features](#)

[Components](#)

[Specifications](#)

[Dimensions](#)

Overview:

Get the Advantages of a EVS Mill at a very Affordable Price.

Clausing's line of Heavy Duty EVS Mills are easy to operate, require less maintenance than mechanical variable speed machines and offer features found only on higher priced EVS Mills...

- Quick and accurate rpm setting
- Convenient, head mounted, easy to use control panel
- LCD spindle speed display
- Spindle brake w/-auto power off
- Totally enclosed electrics with Yaskawa A.C. inverter variable speed drive
- Up to 4 hp spindle motor
- Carbon steel, hardened and ground, chrome plated quill
- Up to 11" x 58" table size
- Meehanite castings for superior rigidity
- Hardened and ground table with 3 ground T-slots
- Double nuts easy backlash adjustment
- Up to 38.25" X-axis travel, 16" Y-axis travel, 17.7" knee travel and 5" quill travel
- All ways are hardened and ground with Turcite B coating on X and Y axis ways for ware resistance and smooth operation

[Return to Top](#)

Features:

- Meehanite castings for superior rigidity and wear resistance
- Hardened and ground ways
- Ground ram ways
- Column & knee way covers
- Hardened and ground table surface
- Ground T-slots to provide reference edge for positioning workpiece
- Hardened and ground spindle
- Hardened, ground and chromed quill
- Hardened X & Y axis leadscrew and Nickel Phosphorous treated
- Coolant system with pump switch
- Flexible segmented coolant nozzle
- 3hp AC motor on 400EVS & 450EVS optional 4hp AC motor for 450EVS
- 4hp AC motor on 500EVS
- Yaskawa inverter variable speed drive
- Dovetail X, Y & Z axis ways on 400EVS
- Square Y-axis ways and dovetail X & Z axis ways on 450EVS
- Square Y & Z axis ways and dovetail X-axis ways on 500EVS
- Lever operated manual rapid quill movement
- Handwheel for fine quill feed
- Adjustable automatic feed disengagement for quill feed in both direction
- Micrometer depth stop
- Reversing switch for clockwise or counter clockwise operation
- R-8 or ISO 30 spindle
- Spindle hand brake w/-auto power off
- One-shot lubrication
- Test and accuracy chart
- Tools, tool kit, operation and parts manuals

[Return to Top](#)

Components:

Head mounted easy to use control



The LCD Display



allows the operator to select spindle speeds quickly and accurately

[Return to Top](#)

Specifications:

MODELS	400EVS	450EVS	500EVS
TABLE			
Table Size	10" x 50" (254 x 1270mm)	10" x 54" (254 x 1372mm)	11" x 58" (254 x 1473mm)
No. of T-slots	3	3	3
T-slot width	.63" (16mm)	.63" (16mm)	.63" (16mm)
T-slot center distance	2.48" (63mm)	2.48" (63mm)	2.48" (63mm)
TRAVELS			
X axis, longitudinal	35" (889mm)	34.6" (879mm)	38.2" (970mm)
Y axis, cross	16" (406mm)	16" (406mm)	16" (406mm)

Z axis, knee	16" (406mm)	16" (406mm)	17.7" (450mm)
Ram travel	22" (559mm)	22" (559mm)	22" (559mm)
Ram swivel	360°	360°	360°
Spindle to column	5.9"-28.9" (150 - 734mm)	5.8"-28.9" (147 - 734mm)	5.3"-27.2" (135 - 691mm)
Spindle nose to table	3.54"-19.7" (90 - 500mm)	3.54"-19.7" (90 - 500mm)	1.57"-19.2" (40 - 489mm)
SPINDLE HEAD			
Spindle drive motor	3 hp (2.25 kw)	3 hp (2.25 kw)	4 hp (3 kw)
Spindle speed range	50-5000 rpm	50-5000 rpm	50-5000 rpm
Spindle taper	R8 or ISO30	R8 or ISO30	R8 or ISO30
Quill travel	5" (127mm)	5" (127mm)	5" (127mm)
Quill diameter	3.28"(83mm)	3.38" (83mm)	3.38" (83mm)
Quill feed (in/rev)(mm/rev)	.00157"/.00315"/.006" (.004"/.08"/.152)		
Head tilt (front or back)	45°	45°	45°
Head tilt (left or right)	90°	90°	90°
DIMENSIONS AND WEIGHT			
Column turret diameter	15.75" (400mm)	15.75" (400mm)	16.54" (420mm)
Knee width	13.75" (349mm)	15.35" (390mm)	15.35" (390mm)
Knee bearing length	17.72" (450mm)	17.72" (450mm)	19.69" (500mm)
Saddle length	20.08" (510mm)	25.59" (650mm)	25.59" (650mm)
Table bearing length	11.26" (286mm)	11.26" (286mm)	11.02" (280mm)
Ram/turret bearing length	17.72" (450mm)	17.72" (450mm)	17.72" (450mm)
Machine weight	2,640 lbs (1198 kg)	2,750 lbs (1247 kg)	3,300 lbs (1497 kg)
Shipping weight	3,040 lbs (1379 kg)	3,150 lbs (1429 kg)	3,700 lbs (1678 kg)

Specification and design subject to change without notice

[Return to Top](#)

Dimensions:

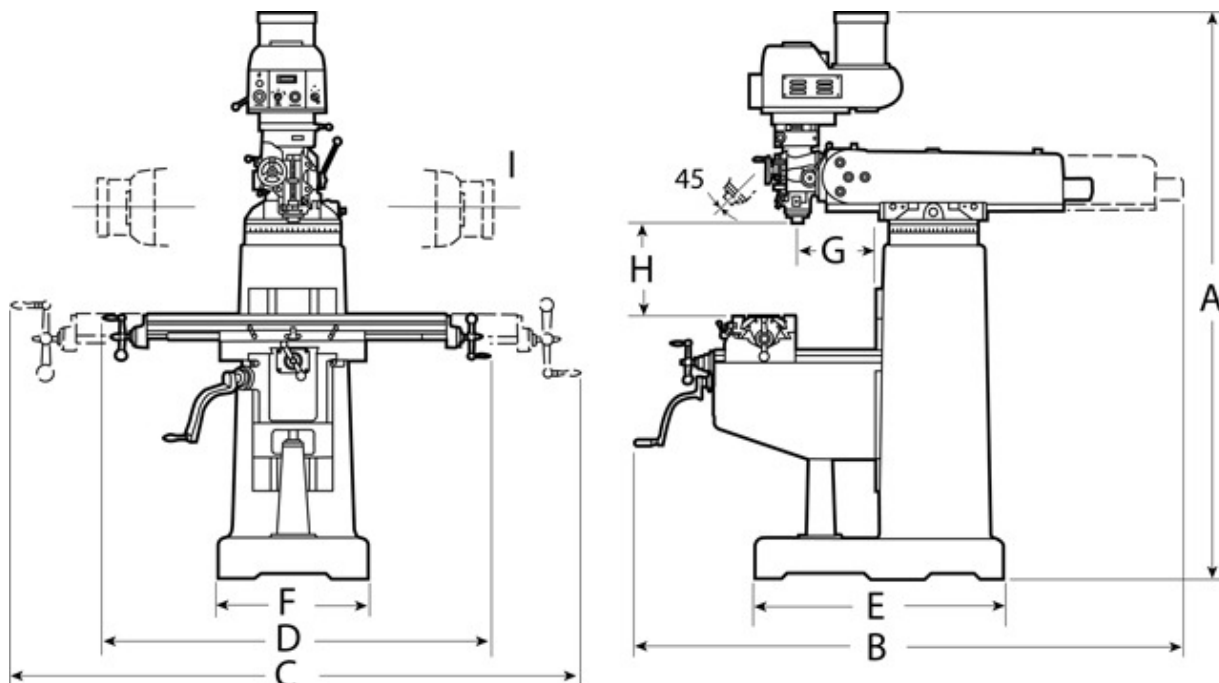

MODEL	400EVS	450EVS	500EVS
A height	88.6"(2250mm)	88.6"(2250mm)	90.6"(2300mm)
B depth w/ram travel	78"(1980mm)	78"(1980mm)	82.7"(2100mm)
C width w/table travel	102"(2590mm)	105"(2667mm)	110"(2795mm)
D width	66"(1676mm)	70"(1778mm)	74"(1880mm)

E base depth	39"(990mm)	39"(990mm)	44"(1118mm)
F base width	23.6"(600mm)	23.6"(600mm)	25"(635mm)
G spindle to column	5.9"-28.9" (150-735mm)	5.9"-28.9" (150-735mm)	5.3"-27.2" (135-690mm)
H spindle to table	3.54"-19.7" (90-500mm)	3.54"-19.7" (90-500mm)	1.57"-19.2" (40-488mm)
I head tilt	90° right or left		

[Return to Top](#)