

Clausing CNC EVS MILLS

[Features](#)

[Machine Specifications](#)

[Dimensions](#)

[Control](#)

with Programmable
Spindle Speeds

ACU-RITE®

A Line of Affordable, Heavy-duty
CNC Vertical Mills with the
Advantage
of Programmable Spindle Speeds



MILLPWR

Two or Full Three
axes CNC Control



Features:

CNC Mills with an Unbeatable List of Standard Features

- ACU-RITE MILLPWR two or full three axes CNC control
- Manual operation with DRO, semi-automatic operation or two or three axes operation
- Up to 4 hp spindle motor standard
- Spindle brake with auto power off
- Totally enclosed electric's with Yaskawa A.C. inverter variable speed drive
- Carbon steel, hardened and ground, chrome plated quill
- Coolant system
- Up to 11" x 58" table size
- Meehanite castings for superior rigidity
- Hardened and ground table with 3 ground T-slots
- Double nuts for easy backlash adjustment
- Up to 35.5" X axis travel, 16" Y axis travel, 17.7" knee travel and 4.75" quill travel
- All ways are hardened and ground with Turcite B coating on X and Y axis ways for wear resistance and smooth operation

[Back to Top](#)**Machine Specifications:**

Model	400EVS	450EVS	500EVS
TABLE			
Table Size	10" x 50" (254x1270mm)	10" x 54"(254x1270mm)	11" x 58"(254x1270mm)
No. of T-slots	3	3	3
T-slot width	.63"(16mm)	.63"(16mm)	.63"(16mm)
T-slot center distance	2.48"(63mm)	2.48"(63mm)	2.76"(70mm)
Table load capacity	700(318kg)	880(400kg)	990(450kg)
TRAVELS			
X axis, longitudinal	32.3"(820mm)	31.9"(810mm)	35.5"(902mm)
Y axis, cross	16"(406mm)	16"(406mm)	16"(406mm)
Z axis, knee	16"(406mm)	16"(406mm)	17.7"(450mm)
Ram travel	22"(559mm)	22"(559mm)	22"(559mm)
Ram swivel	360°	360°	360°
Spindle to column (G)	5.9"-28.9" (150-734mm)	5.9"-28.9"(150-734mm)	5.3"-27.3"(135-691mm)
Spindle nose to table (H)	3.54"-19.7" (90-500mm)	3.54"-19.7"(90-500mm)	1.57"-19.2"(40-489mm)
SPINDLE HEAD			
Spindle drive motor	3 hp(2.25Kw)	3 hp(2.25Kw)	4 hp(35Kw)
Spindle speed range	50-5000 rpm	50-5000 rpm	50-5000 rpm
Spindle taper	R8 or ISO30	R8 or ISO30	R8 or ISO30
Quill travel	4.75"(120mm)	4.75"(120mm)	4.75"(120mm)
Quill diameter	3.28"(83mm)	3.38"(83mm)	3.38"(83mm)
Quill feed	.00157/.00315/.006in/rev (0.04/.08/.152mm/min)		
Head tilt (front or back)	45°	45°	45°
Head tilt (left or right) (I)	90°	90°	90°
DIMENSIONS AND WEIGHT			
Column turret diameter	15.75"(400mm)	15.75"(400mm)	16.54"(420mm)
Knee width	13.75"(349mm)	15.35"(390mm)	15.35"(390mm)
Knee bearing length	17.72"(450mm)	17.72"(450mm)	19.69"(500mm)
Saddle length	20.08"(510mm)	25.59"(650mm)	25.59"(650mm)
Table bearing length	11.26"(286mm)	11.26"(286mm)	11.02"(250mm)
Ram/turret bearing length	17.72"(450mm)	17.72"(450mm)	17.72"(450mm)
Height (A)	88.6"(2250mm)	88.6"(2250mm)	90.6"(2300mm)
Depth w/ram travel (B)	78"(1980mm)	78"(1980mm)	82.7"(2100mm)
Width w/table travel (C)	102"(2590mm)	105"(2667mm)	110"(2795mm)
Width (D)	66"(1676mm)	70"(1778mm)	74"(1880mm)
Base depth (E)	39"(990mm)	39"(990mm)	44"(1118mm)
Base width (F)	23.6"(600mm)	23.6"(600mm)	25"(635mm)
Machine weight	2,640 lbs(1198kg)	2,750 lbs(1247kg)	3,300 lbs(1497kg)
Shipping weight	3,040 lbs(1379kg)	3,150 lbs(1429kg)	3,700 lbs(1678kg)

Specifications subject to change without notice

[Back to Top](#)**Dimensions:**

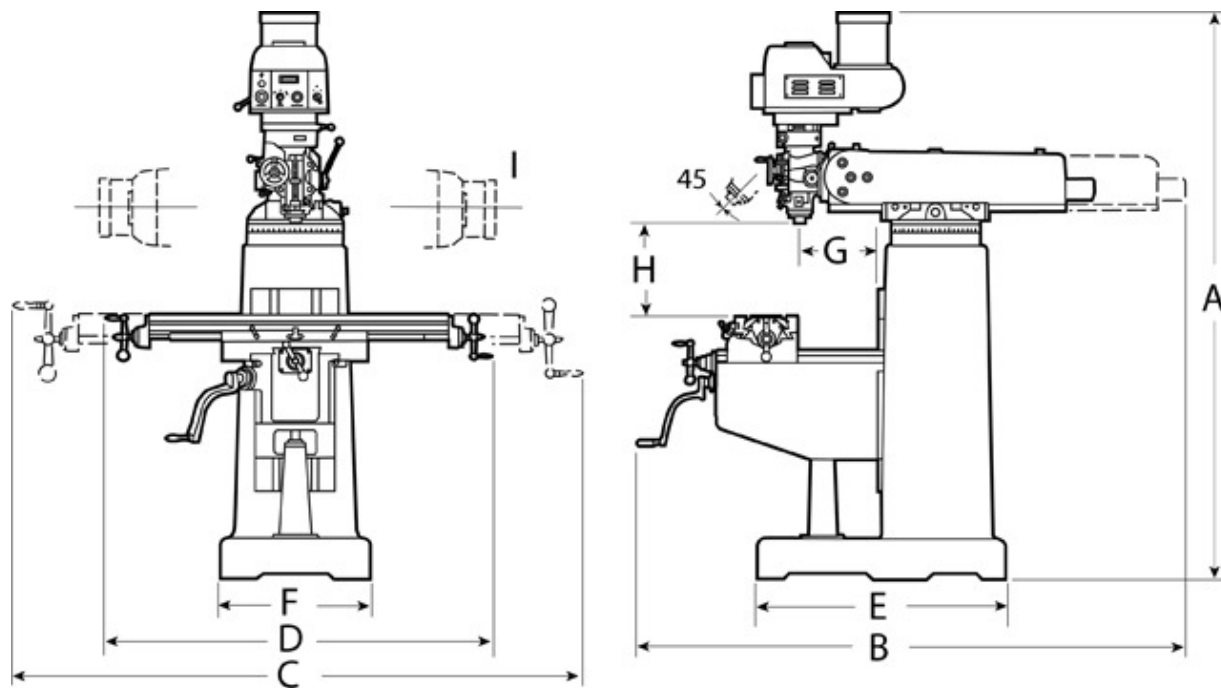

[Back to Top](#)